



INSTALLATION MANUAL

COPYRIGHT ©1998-2008 COMANCHE GEAR - ALL RIGHTS RESERVED

400 COMANCHE MUFFLERS
24484-000 & 24484-010

COMANCHE GEAR



10340 REGENT CIRCLE ∞ NAPLES, FL 34109 ∞ MKURKE@COMANCHEGEAR.COM
PHONE & FAX 239/593-6944 ∞ CELL 239/404-7524

PLEASE NOTE THE FOLLOWING

IT IS IMPORTANT TO INSTALL ONE **#15 SPACER** BETWEEN THE TWO *MUFFLER SUPPORT TUBES* FOR EACH MUFFLER. IF YOU DON'T, THAT PORTION OF THE MUFFLER WHERE THESE BRACKETS ATTACH WILL BE COMPROMISED WHEN YOU TIGHTEN THE SECURING HARDWARE. IF YOU DON'T HAVE THE **#15 SPACER**, THEY CAN BE MADE IN A LATHE FROM A LARGE DIAMETER LOW GRADE [SOFT] BOLT WITH A CLEARANCE HOLE FOR THE AN3 BOLT; ABOUT 1/8" THICKNESS IS CORRECT.

ADDITIONALLY, THE HOLE IN THE MUFFLER AFT SUPPORT WHERE THE *MUFFLER SUPPORT TUBES AND CLAMPS* ATTACH HAS PURPOSEFULLY NOT BEEN DRILLED BY THE OVERHAULING AGENCY AT MY REQUEST; THE REASON IS THAT IT MAY BE DONE INCORRECTLY. USE THE LARGE GIRDLE CLAMPS [*MUFFLER SUPPORT TUBE CLAMP #'S 21 & 22*] AS A DRILLING PATTERN, BUT ALSO KEEP IN MIND THEY ARE DIFFERENT FOR THE LEFT AND RIGHT SIDES. THINK TWICE – DRILL ONCE. USE A HIGH-TEMPERATURE ANTI-SEIZE COMPOUND IN THE FORWARD AREA WHERE EACH *CROSS OVER TUBE* CONNECTS WITH ITS *STACK ASSEMBLY*. THE **LEFT** MUFFLER HAS THE TAB THAT IS USED TO SECURE THE SHROUD CLIP; THIS TAB IS **OFFSET** 16.5° FROM THE CENTER-LINE DRAWN THROUGH THE TWO INLETS.

ALSO PLEASE BE CAREFUL DURING ASSEMBLY; THE ALIGNMENT OF EITHER *CROSS OVER PIPE* AND THE ASSOCIATED *STACK ASSEMBLY* WILL DICTATE THE ROTATION OF THE MUFFLER WHICH WILL AFFECT TWO ISSUES.

- 1) THE POTENTIAL INTERFERENCE OF THE HEAT SHROUD WITH ITS SURROUNDINGS, ESPECIALLY THE RIGHT SIDE MUFFLER. THE TAB THAT IS USED AS A SAFETY ANCHOR FOR THE SHROUD CLIP IS WELDED IN THE CORRECT POSITION [UNLESS YOU SWITCHED THE MUFFLERS LEFT AND RIGHT SIDES]; THIS NEEDS A SMALL HOLE DRILLED FOR THE SAFETY WIRE.
- 2) THE *MUFFLER SUPPORT TUBES* MAY NOT "LINE UP" AND INSTALL CORRECTLY.

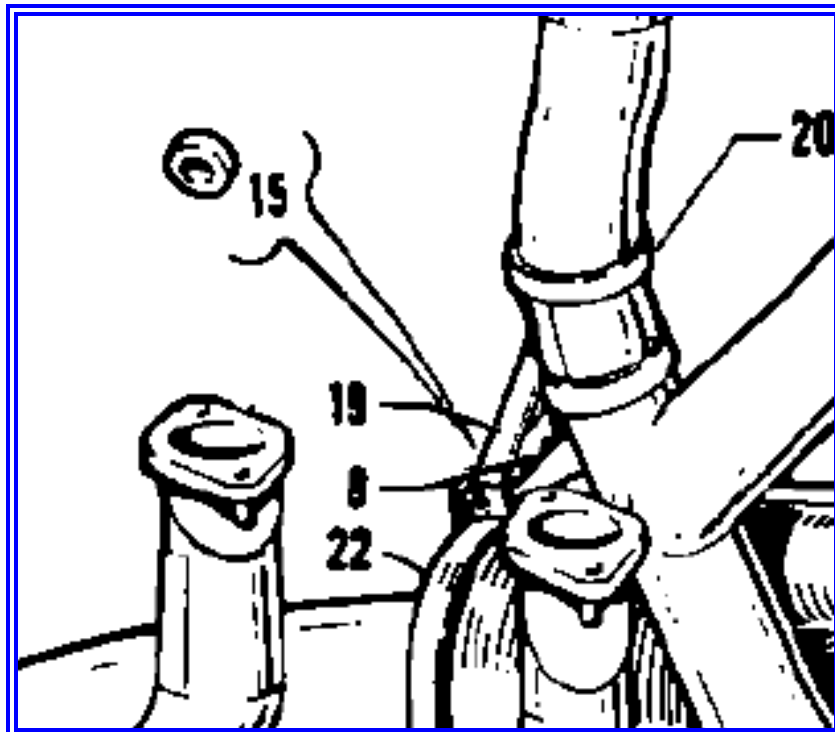

COMANCHE GEAR



10340 REGENT CIRCLE ∞ NAPLES, FL 34109 ∞ MKURKE@COMANCHEGEAR.COM
 PHONE & FAX 239/593-6944 ∞ CELL 239/404-7524

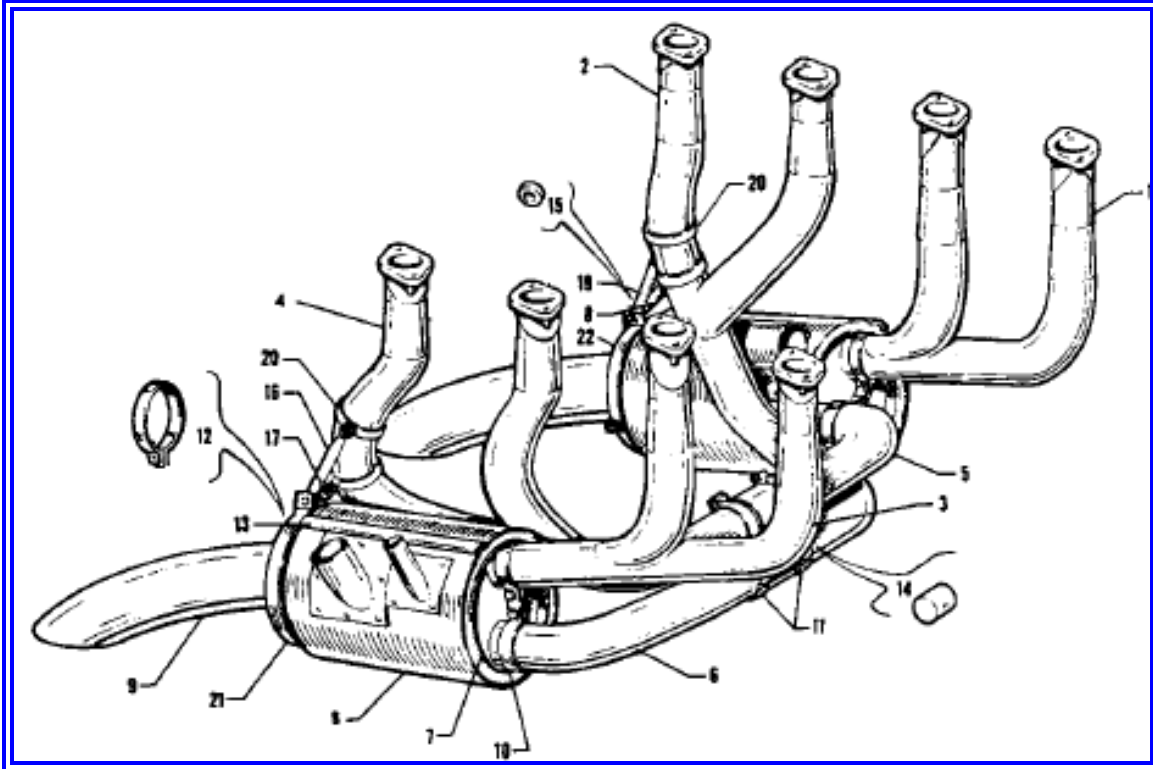

27B-	24537	DRAWING - Exhaust System Installation		
-1	23500-12	STACK ASSEMBLY - Left front	1	
-2	23500-14	STACK ASSEMBLY - Left rear	1	
-3	23500-13	STACK ASSEMBLY - Right front	1	
-4	23500-15	STACK ASSEMBLY - Right rear	1	
-5	23500-10	TUBE - Cross over, left	1	
-6	23500-11	TUBE - Cross over, right	1	
-7	24484-00	MUFFLER ASSEMBLY - Left	1	
	24484-01	MUFFLER ASSEMBLY - Right	1	
-8	24280-00	SHROUD ASSEMBLY - Left	1	
	24281-00	SHROUD ASSEMBLY - Right	1	
-9	24512-00	TAILPIPE - Left	1	
	24513-00	TAILPIPE - Right	1	
-10	24269-00	CLAMP ASSEMBLY - Exhaust stack	2	
-11	23499-00	CLAMP - Exhaust stack	2	
-12	21167-03	CLAMP - Tailpipe	2	
-13	24279-00	CLIP - Muffler shroud	2	
-14	23501-00	SPACER - Exhaust stack clamp	4	
-15	61402-72	BUSHING - Support tube spacer	2	
-16	24515-00	TUBE - Right muffler support	1	
-17	24516-00	TUBE - Right muffler support	1	
-18	24517-00	TUBE - Left muffler support	1	
-19	24518-00	TUBE - Left muffler support	1	
-20	80002-79	CLAMP - Muffler support tube	4	26-2 to 26-124 inclusive
	14235-12	CLAMP - Muffler support tube	4	26-125 and up
-21	24996-02	CLAMP - Muffler support tube, left	1	
	24996-03	CLAMP - Muffler support tube, right	1	
-22	24996-04	CLAMP - Muffler support tube, left	1	
	24996-05	CLAMP - Muffler support tube, right	1	

COMANCHE GEAR



10340 REGENT CIRCLE ∞ NAPLES, FL 34109 ∞ MKURKE@COMANCHEGEAR.COM
PHONE & FAX 239/593-6944 ∞ CELL 239/404-7524



RIGHT SIDE MUFFLER SUPPORT TUBES AND CLAMPS POSITION



LEFT SIDE MUFFLER SUPPORT TUBES AND CLAMPS POSITION

COMANCHE GEAR



10340 REGENT CIRCLE ∞ NAPLES, FL 34109 ∞ MKURKE@COMANCHEGEAR.COM
PHONE & FAX 239/593-6944 ∞ CELL 239/404-7524



TAIL PIPES - RIGHT SIDE PICTURED ABOVE RIGHT

