

COMANCHE GEAR



10340 REGENT CIRCLE ∞ NAPLES, FL 34109
PHONE & FAX 239/593-6944 ∞ CELL 239/404-7524
MKURKE@COMANCHEGEAR.COM

FUEL QUANTITY INDICATOR SELECTOR SERVICE

IF YOU ARE EXPERIENCING A PROBLEM WITH THE FUEL QUANTITY INDICATOR SELECTOR SYSTEM LOCATED AS PART OF THE FUEL VALVE PROTECTOR PLATE, HERE IS A SERVICE TO REPLACE THE SWITCHES AND WIRING WITH NEW. AN INCLUDED ADDITION TO MAKE REMOVAL AND INSTALLATION EASIER IS A RECEPTACLE/PLUG CONNECTOR SET, SEE THE PHOTO BELOW. NO LONGER DO YOU HAVE TO DEAL WITH DAMAGING THE PROTECTOR PLATE DURING ANNUAL, JUST UN-PLUG IT AND GET IT OUT OF THE WAY. ADDITIONALLY INCLUDED IS 1' OF EACH WIRE ON THE AIRFRAME SIDE OF THE CONNECTOR.

THERE ARE 2 WAYS TO HANDLE THIS.

1) SEND YOUR OLD PROTECTOR PLATE ASSEMBLY TO ME AND I WILL REFURBISH WITH NEW SWITCHES AND WIRING.

2) I WILL SEND TO YOU A NEW SWITCHES ASSEMBLY AND YOU INSTALL INTO YOUR PROTECTOR PLATE.

THE SERVICE INCLUDES A COMPLETE INSTALLATION MANUAL WITH DIAGRAMS, PHOTOGRAPHS, AND A SUGGESTED LOG BOOK ENTRY.

ONE-DAY TURN-AROUND; \$80 PLUS PARTS. THE FUEL QUANTITY OVER-RIDE SWITCHES, ARE NOT EXPENSIVE - \$17.50 EACH. THE WAFER SWITCH, CALLED THE SELECTOR SWITCH, IS \$169.39. THOSE PRICES WILL CHANGE WHEN PIPER THINKS IT'S NECESSARY.



**NEW SWITCHES ASSEMBLED WITH PROPERLY-MARKED MS22759 WIRE,
AND ASSEMBLED INTO CONNECTOR SET; MAKES LIFE SLIGHTLY MORE SIMPLE.**

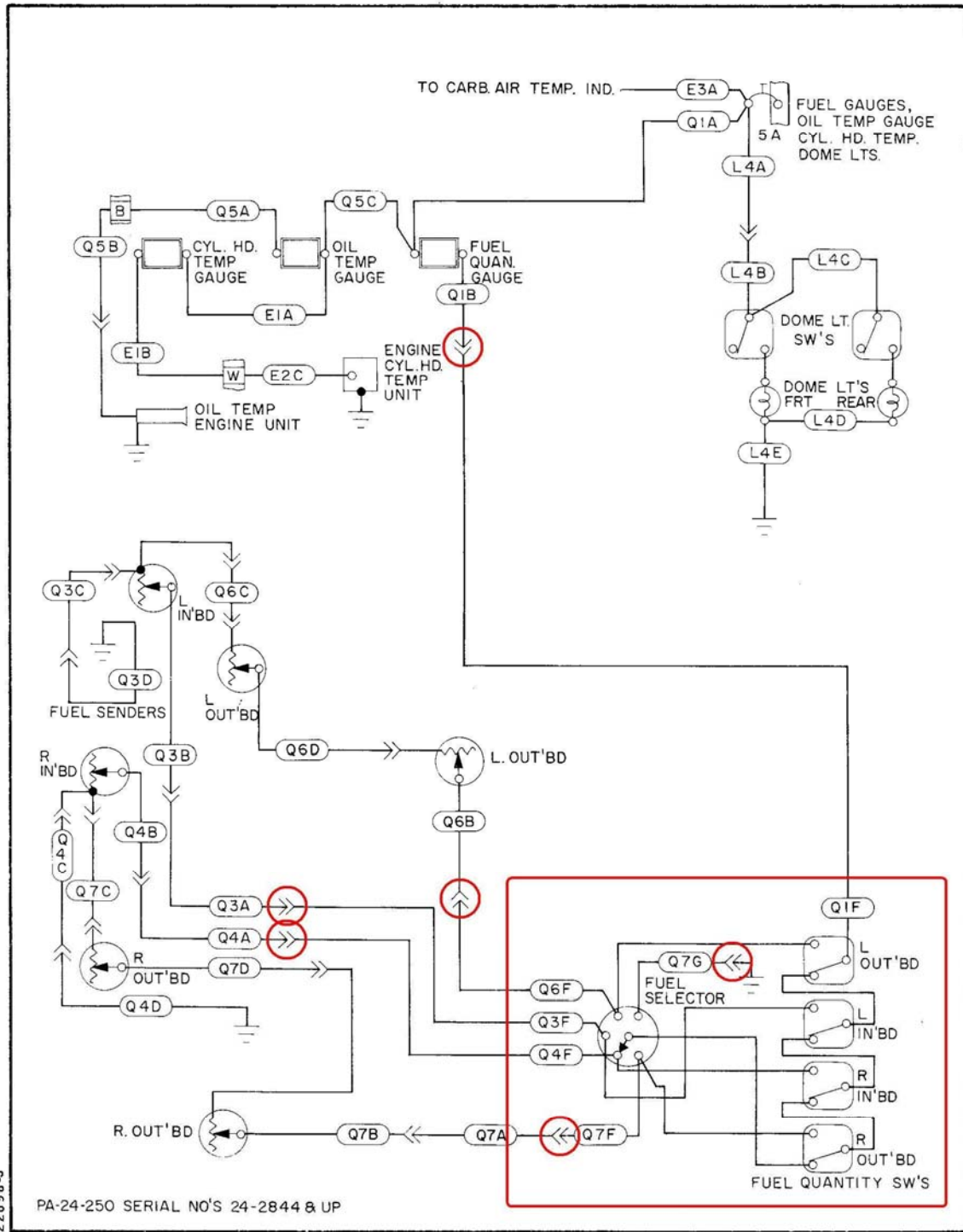

FIGURE 9-41. FUEL GAUGE, OIL TEMP. GAUGE, DOME LIGHT, CYLINDER HEAD TEMP.

ELECTRICAL SYSTEM
ISSUED: 8/18/72

THE RED OUTLINED PORTION ABOVE IS INVOLVED IN THE RE-WIRING OF THE FUEL QUANTITY SELECTOR COVERED IN THIS MANUAL. THE 6 RED CIRCLES INDICATE THOSE CONNECTION POINTS INVOLVED IN THE RECEPTACLE/PLUG ASSEMBLY.

9-57

EXAMPLE OF A WIRING DIAGRAM SUPPLIED WITH THE INSTALLATION MANUAL