

# COMANCHE GEAR



10340 REGENT CIRCLE ∞ NAPLES, FL 34109  
PHONE & FAX 239/593-6944 ∞ CELL 239/404-7524  
[MKURKE@COMANCHEGEAR.COM](mailto:MKURKE@COMANCHEGEAR.COM)



## THREAD GAUGES

1). THESE TOOLS ARE EXPENSIVE AND AN IMPORTANT COMPONENT IN PERFORMING THE SL-782B ADDRESSED IN THE AD 77.13.21 PART A; PLEASE TREAT THEM WITH CARE ADHERING TO THE FOLLOWING SUGGESTIONS. THEY MUST BE RELIED UPON FOR ACCURATE MEASUREMENTS FOR YOU AND FOLLOWING USERS. THESE ARE NOT “THREAD CHASERS”; USE THEM ONLY ON PERFECTLY CLEAN THREADS, SLIGHTLY OILED. I SUGGEST USING A BRASS BRUSH AND SOLVENT TO CLEAN THE MALE THREADS, AND A GUN-CLEANING BRONZE BORE BRUSH FOR CLEANING THE FEMALE THREADS. DO NOT, DO NOT, DO NOT USE THE TOOLS TO CLEAN THESE THREADS!

2). USE CAUTION WHEN HANDLING THESE TOOLS; DROPPING EITHER CAN RENDER IT INACCURATE AND NO ONE WOULD KNOW. USE THEM OVER A PADDED WORK AREA. I DO NOT HAVE A “STANDARD” TO TEST THESE GAUGES.

3). DO NOT FORCE EITHER GAUGE ONTO OR INTO THE THREADS BEING CHECKED.

A. IF THE THREAD PLUG GAUGE [0.4731” OR 0.5764”] WILL SCREW INTO THE APPROPRIATE ROD END BEARING EASILY, THOSE THREADS ARE WORN BEYOND THE LIMIT; OBTAIN SERVICEABLE REPLACEMENT COMPONENT. IF IT ENCOUNTERS RESISTANCE THEN **STOP – DO NOT CONTINUE MOVING THE GAUGE INTO THE THREADS**, THOSE THREADS ARE WITHIN THE LIMIT.

B. IF THE THREAD RING GAUGE [0.4550” OR 0.5764”] WILL SCREW ONTO THE APPROPRIATE DRAG LINK EASILY THOSE THREADS ARE WORN BEYOND THE LIMIT; OBTAIN SERVICEABLE REPLACEMENT COMPONENT. IF IT ENCOUNTERS RESISTANCE THEN **STOP – DO NOT CONTINUE MOVING THE GAUGE ONTO THE THREADS**, THOSE THREADS ARE WITHIN THE LIMIT.

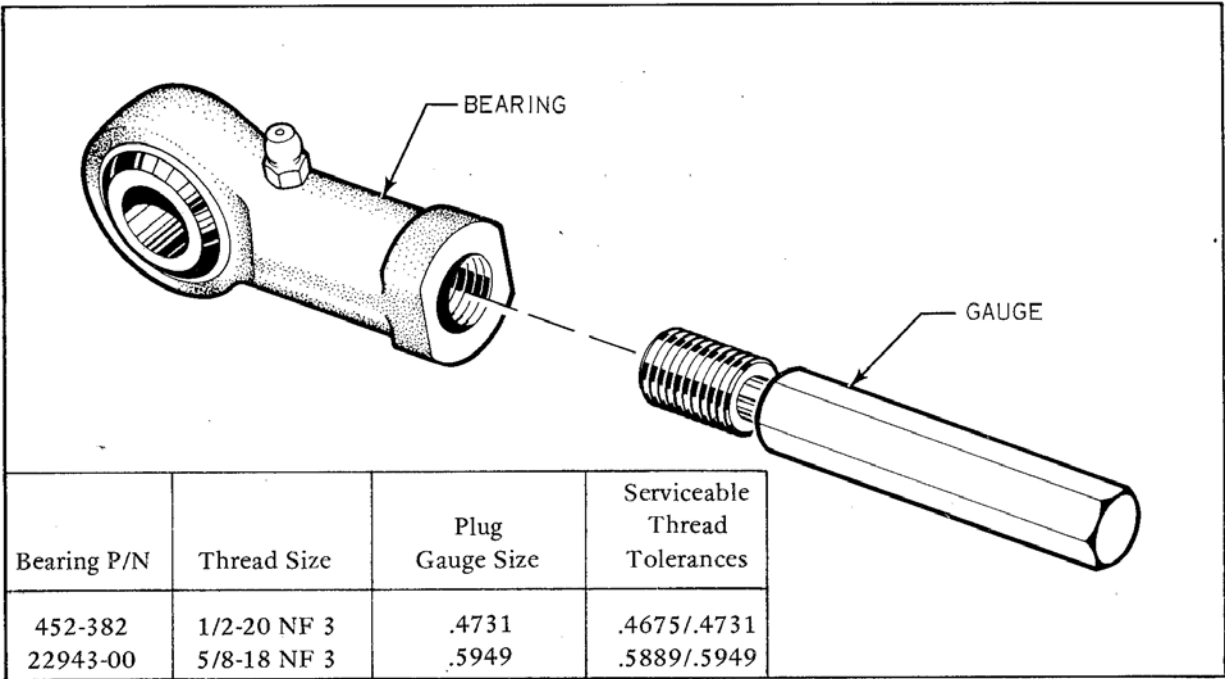

FIGURE 6-8b. MAIN GEAR SIDE BRACE BEARING TOLERANCE

Link P/N	Thread Size	RING GAUGE SIZE	Serviceable Thread Tolerances
20768-00	1/2-20 NF 3	1/2-20	.4675/.4550
20768-01	1/2-20 NF 3	1/2-20	.4675/.4550
24911-00	1/2-20 NF 3	1/2-20	.4675/.4550
22577-00	5/8-18 NF 3	5/8-18	.5889/.5764
25046-00	5/8-18 NF 3	5/8-18	.5889/.5764

MAIN GEAR SIDE BRACE LINK TOLERANCE CHART; TYPICAL FROM THE SERVICE MANUALS.



**MAIN GEAR SIDE BRACE LINK AND THREAD RING GAUGE.**



**MAIN GEAR SIDE BRACE LINK AND THREAD RING GAUGE; WITHIN THE LIMIT.  
READ #3-B ON THE FIRST PAGE.**