

# COMANCHE GEAR



10340 REGENT CIRCLE ∞ NAPLES, FL 34109  
PHONE & FAX 239/593-6944 ∞ CELL 239/404-7524  
[MKURKE@COMANCHEGEAR.COM](mailto:MKURKE@COMANCHEGEAR.COM)

## ADJUSTMENT HINT FOR THE LIMIT SWITCHES

**IT IS IMPORTANT TO GET THIS ADJUSTMENT RIGHT!!** THE LIMIT SWITCHES' ADJUSTMENT PROCEDURE IS SOMEWHAT VAGUE IN THE COMANCHE SERVICE MANUALS; THE FOLLOWING IS A SUGGESTION THAT MAY BE OF SOME HELP AND CLARIFICATION. WITH THE GEAR PARTIALLY-RETRACTED AND THE UPPER LINK DISCONNECTED FROM THE SIDE-BRACE STUD, IT IS POSSIBLE TO MIMIC THE KNEE ACTION BETWEEN THE UPPER AND LOWER LINK ASSEMBLIES. MAKE THIS ADJUSTMENT SO THE SWITCHING ACTION TAKES PLACE AT THE DIAGRAMMED VALUE SHOWN; I.E. FOR THE MAINS  $0.125''+0.06''-0.00''$  AND FOR THE NOSE  $0.187''+0.062''-0.00''$ , BEFORE THE "DOWN AND LOCKED" POSITION. WORN BUSHINGS HERE WILL FRUSTRATE THIS ADJUSTMENT ESPECIALLY FOR THE RECTANGULAR SWITCH VERSIONS. TRIPLE-CHECK THIS IMPORTANT ADJUSTMENT FOR YOUR CONFIDENCE AND YOU WON'T HAVE TO GO BACK OR WONDER ABOUT IT AGAIN.

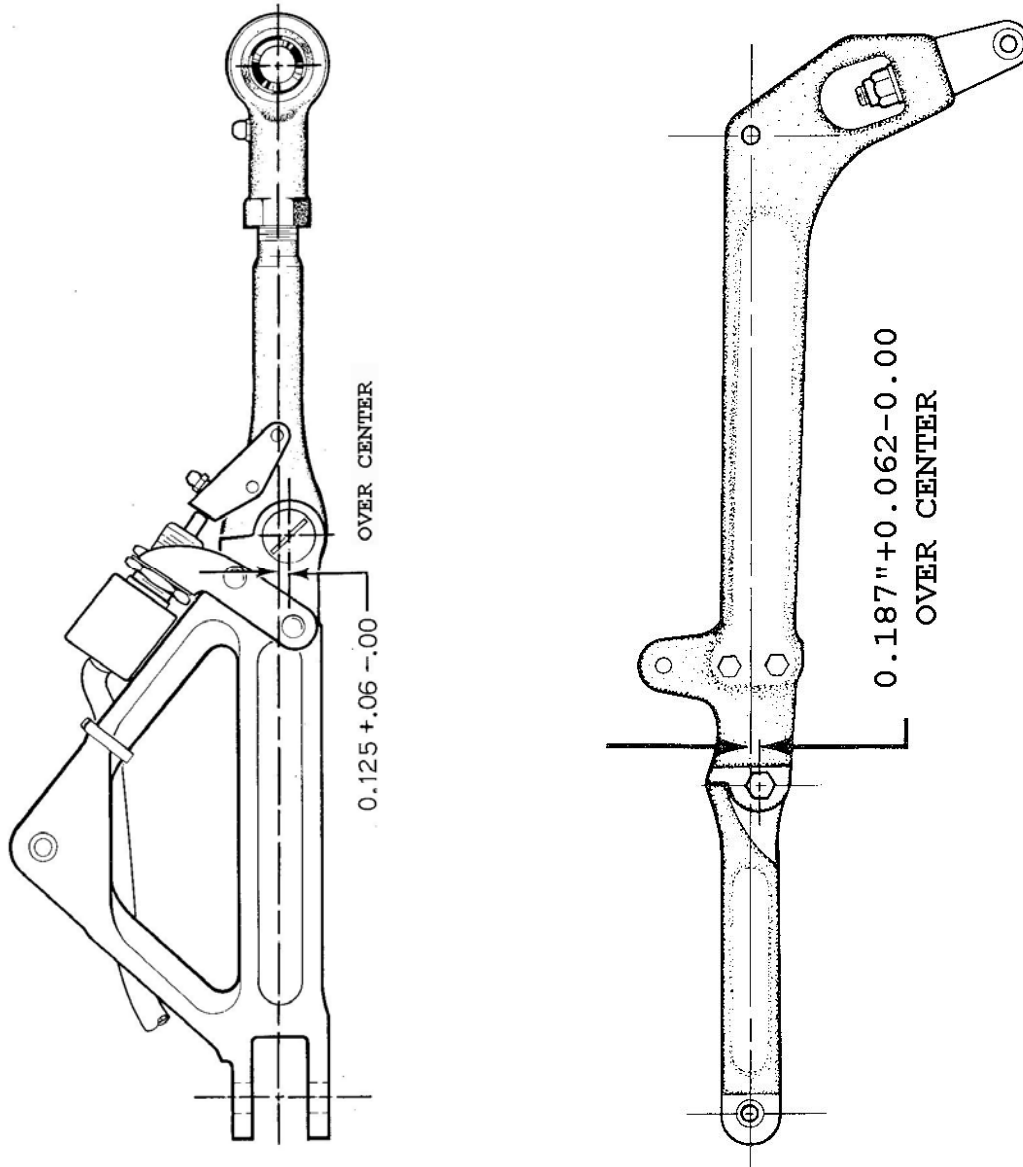



IF YOU ARE WORKING ON A ROUND-SWITCH VERSION AIRFRAME, USE THE FOLLOWING AS A BASIC SETTING FOR INSTALLING THE MAIN GEAR LIMIT SWITCHES. ADJUST THE NUT POSITION SO THERE IS 0.525 INCH BETWEEN THE BASE OF THE MICRO SWITCH AND ITS MOUNTING BRACKET. THIS WORKS PRETTY WELL AS A STARTING POINT HOWEVER DON'T LET THIS SUGGESTION BE A SET-IT-AND-FORGET-IT. TRIPLE-CHECK THIS IMPORTANT ADJUSTMENT FOR YOUR CONFIDENCE AND YOU WON'T HAVE TO GO BACK OR WONDER ABOUT IT AGAIN.

